

Why is Swiss Politics so Stable?

PETER MOSER*

1. INTRODUCTION

Switzerland has long been admired for its political stability. Swiss politics is predictable in the sense that major policy changes are regarded as very unlikely to occur. This characteristic proved to be a major advantage because it provided stable property rights. In recent years, however, Swiss economic policy has been criticized for its lack of actions in face of worldwide deregulation which has eroded traditional advantages of Switzerland (see for example BORNER, BRUNETTI and STRAUBHAAR 1990). The same groups that benefitted from the political stability, now seem to be harmed by its immobility. Not surprisingly, a number of proposals have been advanced that aim at changing the political process (BORNER, BRUNETTI and STRAUBHAAR 1990, 1994, BORNER, PORTER, WEDER and ENRIGHT 1991, GERMANN 1990 and 1994, KLEINWEFERS 1995, KÖLZ and MÜLLER 1990, LINDER 1994, MOSER 1991, WITTMANN 1992) and some of these proposals have been included in the recent proposition for a new Constitution by the Federal Government (BUNDES RAT, 1995). However, all these proposals are ad hoc in the sense that they are not based on a comprehensive and theoretically rigorous analysis of the political system. In this paper, I take a first step into this direction by applying a methodology that allows to analyze major aspects of the Swiss political system.¹

This analysis is based on the methodology and on major results of *spatial models of political choices*, sometimes referred to as *Positive Political Theory*. This theory is part of the Public Choice literature and assumes that individuals act rationally and are forward looking within given constraints (see MUELLER 1989, chapter 5, and for a recent textbook ORDESHOOK 1992 and FREY and KIRCHGÄSSNER 1994, chapter 5). A principal lesson is that majority-based voting systems have no natural resting place or «equilibrium» (MCKELVEY 1976). In general, no policy commands a majority against all other feasible proposals, and consequently, any status quo is potentially replaceable. Political stability

* SIASR, University of St. Gallen, Dufourstr. 48, CH-9000 St. Gallen. Phone: ++41 71 224 329, e-mail: MOSERPE@ siasr.unisg.ch.

I am grateful to BARRY WEINGAST for helpful discussions, and to SIMON HUG and to an anonymous referee for valuable comments.

1. I do not focus on the normative issue of the optimal degree of stability. Obviously, stability is not the same as efficiency (see BRUNETTI 1992 for an extensive discussion on this issue). However, in the absence of stability-generating institutions governments are likely to use fiscal policy variables to bind their successors (PERSSON and SVENSSON 1989, ALESINA and TABELLINI 1990). As a consequence, a government may run an excessive budget deficit with corresponding efficiency losses.

can be induced by the structure of the political decision. This type of equilibrium is called *structure-induced equilibrium* and a variety of such equilibria have been discovered. Since the overwhelming part of the literature focuses on the political system of the United States most analyses are drawn from this system. Stability-providing institutions are found to be the American separation of powers (HAMMOND and MILLER 1987) and the committee system in Congress (SHEPSLE and WEINGAST 1987). In general, the more veto players exist the more stable is a political system (TSEBELIS 1995). Direct democracy has not drawn much attention until recently because it may be regarded as a pure majority rule and therefore would seem unable to generate stable outcomes (see RIKER [1982] critique of populism).² However, as I show in this paper, direct democratic-decision making *combined* with representative forms can in fact induce policy stability.

The paper addresses the impact of legislative and constitutional decision rules for one and two-dimensional policy choices. For legislative decisions, policy stability is increased by the combination of a bicameral parliament (with both chambers having identical legislative rights) with the optional referendum. This gives the people the right to veto policy changes. Such a decision structure creates three veto players (both chambers and the people) and thereby raises stability if the preferences of these players are heterogeneous. As a consequence, a change in the preferences of only one player is in general not sufficient to induce a policy change. Constitutional stability is created by the requirement that amendments have to include a single issue only. This requirement transforms more-dimensional choices into several one-dimensional decisions which in general have an equilibrium. Furthermore, stability is enhanced by the qualified majority rule which requires the support of a majority of the people and of a majority of the cantons for constitutional amendments. A comparison of the legislative and constitutional decision rules reveals that the legislative process tends to be more stable than the constitutional one; a peculiar result that stands in contrast to normative conceptions of a constitution as containing the basic consent-based rules of a state.

Furthermore, the analysis points out that the dominance of status quo preserving groups in Swiss politics may not be due to a conservative bias of voters or due to lower organization costs by conservative than by progressive groups but rather can be explained by the decision rules. For example, the optional referendum is an instrument suited only for groups that want to defend the status quo. However, I show that the threat or the successful use of a referendum is *beneficial* for voters, particularly, if the parliament is uncertain about voters' preferences.

The paper proceeds as follows. In section 2, I give a brief introduction into the methodology. In section 3, the legislative decision making and, in section 4, the

2. An exception is the literature initiated by ROMER and ROSENTHAL (1978), and also STEUNENBERG (1992) who analyzes the impact of referendum and initiative on public expenditure. However in this literature, policy choice is one-dimensional and the agenda setter is usually a single player (for example an executive or a unicameral legislature). Less formally developed but related to the arguments presented her is the work by BLANKART (1992). For empirical studies see POMMERHEHNE (1978) and FELD (1995).

constitutional decision rules are analyzed. Section 5 assesses the impact of two prominent reform proposals, namely the modification to the optional referendum and the introduction of a constitutional review of statutes by the Federal Court. In section 6, I extend the model to include uncertainty. Finally, section 7 is a brief conclusion.

2. METHODOLOGY

The basic ingredients of spatial models include definitions of the choice space, preferences, institutions and equilibria. The objects of choice are represented as points in a *multidimensional space*. Suppose for example that a legislature has to decide about the level of taxes and how to allocate the money between defense and social programs. With a balanced budget requirement, the choice of two variables determine the third variable. Therefore, this choice can be represented by a two-dimensional policy space, where, as in Figure 1a, x_1 and x_2 denote the dimension of defense and social spending, respectively. Consequently, any point on the plane is a potential legislative choice. Each legislator has an *ideal point* in the space (L_1 , L_2 and L_3 in Figure 1a), that is, a most preferred combination of spending and taxation. His or her preferences are determined by the interests and ideologies of his or her constituency. Suppose that each legislator is indifferent between spending combinations that are located at equal distance from his or her ideal point. With this description preferences are Euclidean with *circular indifference curves*.³ The indifference curves through the status quo (Q) are drawn in Figure 1.

All political actors are assumed to be fully informed about the preferences of the other actors and about the structure of the game. Second, it is supposed that the actors dislike if a decision is reversed by others. Third, institutions determine the sequence of the game and, for example, allocate the right to make a proposal and define the decision rule.

Suppose that each of the three legislators in Figure 1 has the right to make a proposal and that the decision rule is unanimity. In this case, no political action will be observed as long as the status quo (Q) is inside the triangle $L_1L_2L_3$: The status quo is a stable policy. However if Q is outside $L_1L_2L_3$ each legislator wants to propose a point which maximizes his or her utility under the constraints that the proposal is inside the triangle – otherwise it is not a durable choice – and that the proposal is preferred by all three decision makers to Q . Which point inside the triangle will be chosen depends on the allocation of the rights to make proposal and counterproposals among the three legislators and on the exact location of Q .

3. Although Euclidean preferences simplify the presentation of the argument, the logic is not affected by more realistic representation of preferences that take into account that a legislator's utility may be more sensitive to a policy change in one dimension than along another or that a legislator's most-preferred point on any given dimension is affected by policy changes in other dimensions (nonseparable preferences). Critical is however, that preferences are single-peaked, that is, that beginning at a legislator's ideal point, utility always declines monotonically in any direction.

Figure 1: Win set in two and one dimensional choices

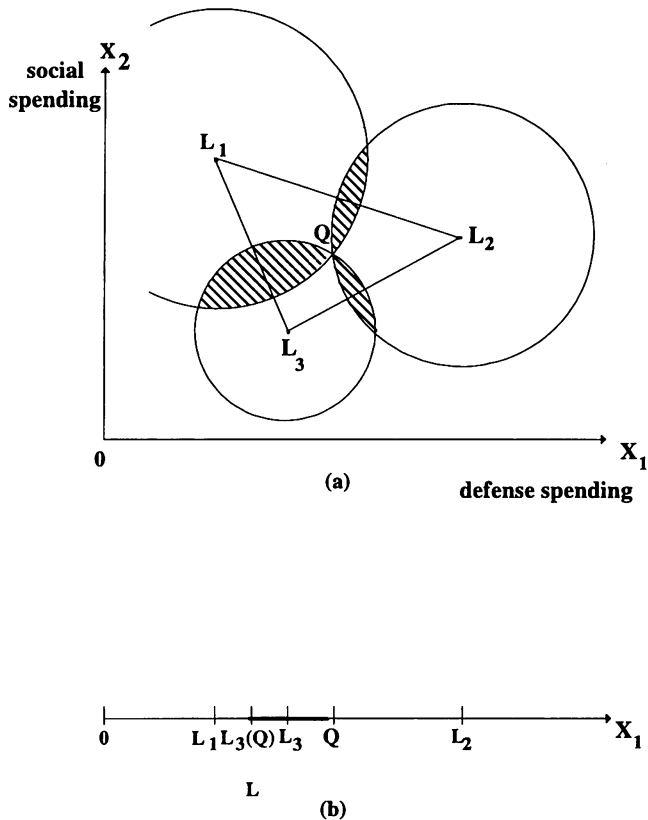

In contrast, if the legislators decide by simple majority rule, political action will be ongoing because in general no point exists which cannot be defeated. As MCKELVEY (1976) has shown, majority rule votes in general can lead to any arbitrary point in the space.⁴ In Figure 1a, the three shaded petals are the set of policy alternatives that are preferred by a majority of the decision makers to Q . This set of points is called the *win set of Q* , $W(Q)$. Notice that any point in the win set is dominated by some other points in the space. The fact that for any point x in the choice space X the win set is nonempty [$W(x) \neq \emptyset, \forall x \in X$] defines the instability of pure majority rules.

Obviously, political choices are much more stable than suggested by the MCKELVEY-theorem. One approach to solve this dilemma is to modify the assumptions, in particular

4. This global cycling result is so extreme because the legislators do not know the agenda and are assumed to vote sincerely at each decision. If the agenda is known in advance forward looking behavior constrains cycling to a centrally located subset of the issue space (see SHEPSLE and WEINGAST 1984).

to incorporate uncertainty. In *probabilistic voting models* (see COUGHLIN 1992) there is uncertainty about the preferences of the decision makers (voters or legislators).⁵ The decisions follow a probability function. If this function is continuous and strictly concave, a unique equilibrium outcome exists. Whether collective decisions are stable depends on the nonobservable form of the probability function. This is one reason why these models often come up short in terms of testable implications. Another avenue has been to argue that repeated interaction allows legislators to build *reputation* and therefore to form stable coalitions (see BERNHOLZ 1978, AXELROD 1984). While reputation surely plays an important role in legislatures, for many settings it may be insufficient because political exchange is often nonsimultaneous and the benefit flows of policies occur over different time horizons (see WEINGAST and MARSHALL 1988). Consequently, scholars have focused on the structure of collective decision rules as a way to induce stability and thereby to complement reputational strategies. SHEPSLE (1979, 1986) has demonstrated that if a decision rule is more structured than by a simple majority rule, an equilibrium may exist which he called *structure-induced equilibrium*. Formally, it is defined as the set of points which have an empty win set. The simplest case are decisions which are constrained to a single dimension. Only the ideal point of the median voter has an empty win set and is therefore an equilibrium. This is illustrated in Figure 1b with L_3 's position being the median with respect to defense spending. If the status quo is between L_3 and L_2 , as drawn, the win set is equal to the set of points between Q and $L_3(Q)$. $L_3(Q)$ is the proposal that keeps the median legislator indifferent to Q . Any points in this win set can defeat Q . But only one point in this win set, namely L_3 , cannot be defeated. Consequently, the median position is the only equilibrium. This is the well known median voter result of BLACK (1958).

Of course, institutions usually constrain decision makers in a more complex way than to force the decisions into a single dimensions. In the following sections, I apply the approach of the structure-induced equilibrium to the political system in Switzerland. This methodology allows to identify in what respect the institutional structure contributes to the stability observed in Swiss politics.

3. LEGISLATIVE DECISION RULES

The legislative decision rules in Switzerland are as follows: Proposals can be initiated by members of both Councils and by the executive⁶. For a legislative proposal to become

5. In these models uncertainty is introduced in a peculiar way: The decision makers can assign utilities to the proposals (or to the platforms of the candidates in elections) but they do not choose the proposal with the highest utility for sure but only with some probability. Implicitly, decision makers must be informed in order to determine the utility of each proposal. Nevertheless, they still choose the inferior proposal with positive probability, that is they make wrong decisions systematically.
6. The executive is a board of 7 persons elected by the parliament in a joint session of both chambers.

law it has to be approved by the Council of States and the National Council⁷. If 50,000 people sign up for a referendum or eight cantons demand a referendum, the proposal is submitted to a simple majority vote. In contrast to many other countries, the Federal Court cannot review federal legislation whether it is in accordance with the Constitution.

I analyze the impact of these rules on the degree of stability, first for single issue decisions and second for decisions that include simultaneously two different issues. For simplicity, I assume that the costs to collect 50,000 signatures are trivial because it requires only the support of about one percent of all voters. Therefore, I suppose for the moment that a referendum takes place whenever the median voter prefers the status quo to the proposal. In section 6, I include the costs of collecting signatures and uncertainty into the model which allows to analyze the strategic interaction between the parliament, interest groups and the median voter.

3.1 *One-dimensional choices*

An example of a one-dimensional choice is given in Figure 2. The ideal points of the medians in both chambers (S and N) will generally not be identical because the regional composition in the two Councils differs and their members are elected under different rules (two member districts with majority rule for the Council of States versus list system with proportional representation for the National Council).⁸ In a pure bicameral system the equilibrium includes all points in the interval $[S, N]$: If the status quo is inside this interval no proposal will be forthcoming because a move to the right would be vetoed by the Council of States and a move to the left by the National Council. With the introduction of the optional referendum a third player exists, namely the people. If the median voter's ideal point (P) is between S and N (as in Figure 2a), the referendum does not change the set of equilibrium points. If P is outside this interval (as in Figure 2b) the equilibrium of the bicameral-referendum game comprises a larger interval than in the bicameral game and includes the set of points between P and N .⁹ The larger the set of

7. The Council of States has 46 members, two for each canton. In contrast, the National Council comprises 200 members which are distributed among the cantons according to their shares of the population, with the requirement that each canton has at least one representative.
8. This is supported by the fact that the party composition in both chambers differs considerably. In the legislative period 1991-95, the two largest conservative parties (FDP, CVP) have together 41 percent of the seats in the National Council but a solid majority of 74 percent in the Council of State. In contrast, the Social Democrats have 22 percent in the National Council but only 9 percent of the seats in the Council of States.
9. One might wonder whether P can lie outside the interval $[S, N]$. Since the small cantons have the same weight as the populous ones in the Council of States, the median member of the Council of States and the median voter do not have the same policy position in general. Less obvious is the deviation between N and P because the National Council's membership is according to the population share of each canton elected by a list system with proportional representation. Nonetheless, the link between voters and representatives is indirect, because a vote first counts for the party list which determines the number of seats for the party and only afterwards decides which candidate receives one of the party seats. How often P is outside the interval $[S, N]$ is of course an empirical question.

Figure 2: Equilibrium in one-dimensional legislative choices

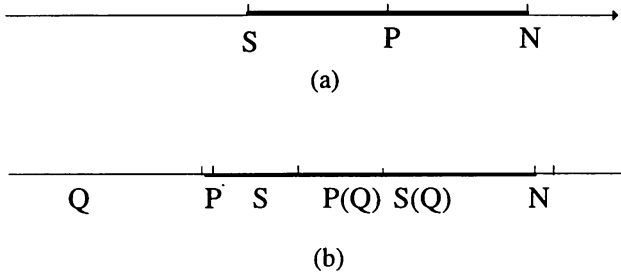

equilibrium points the more likely it is that the status quo is an equilibrium point and no policy change possible. Therefore, the following proposition follows:

PROPOSITION 1: In one-dimensional decisions, the set of equilibrium points in the bicameral-referendum game is at least as large as in the bicameral game.

How much does the optional referendum constrain the two Councils if the status quo is outside the equilibrium? This depends on the position of P . In the case of Figure 2b, P is constraining the bicameral choice, because policy cannot be moved to the right of $P(Q)$, the point that leaves the median voter indifferent to Q . Otherwise, the proposal is vetoed by the people. Hence, the choice of the Council of States and the National Council is restricted to a policy between S and $P(Q)$. Assuming that their bargaining position is equally strong, I supposed that the two chambers agree on a policy that corresponds to the middle of the feasible equilibrium interval $[S, P(Q)]$, that is to $(P(Q) + S)/2$. For the ordering in Figure 2b (with $Q < S < S(Q) < N$), the bold line in Figure 3 characterizes the relationship between the position of P and the outcome. There are four different cases depending on the location of P :

- (i) $P \leq Q : x = Q$
- (ii) $Q < P \leq \frac{Q+S}{2} : x = P(Q)$
- (iii) $\frac{Q+S}{2} < P < S : x = \frac{S+P(Q)}{2}$
- (iv) $P \geq S : x = \frac{S(Q)+S}{2}$

In the first case, where P is at the status quo or to the left, Q is an equilibrium point and no change occurs. If P is between Q and $(Q + S)/2$ both Councils want to move policy as far as possible, that is to $P(Q)$. In the third case, which corresponds to the situation drawn in Figure 2b, the Council of States and the National Council split the distance

between S and $P(Q)$. Finally, if P is at S or to the right the referendum does not restrain the bicameral game and the point in the middle of S and $S(Q)$ is chosen. In the absence of the referenda, the parliament always chooses $(S(Q) + S)/2$ as in case four. Consequently, the referendum has a *status quo-preserving bias* inasmuch as it reduces policy changes in certain conditions and has no impact otherwise.¹⁰ This is precisely stated in the following proposition:

Figure 3: Location of median voter and legislative choice

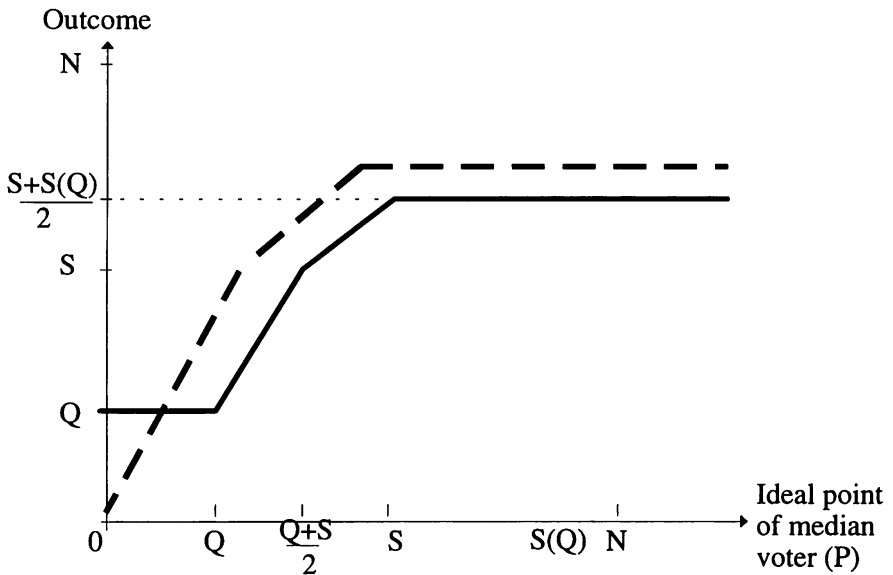

PROPOSITION 2: In one-dimensional decisions, the threat of a referendum prevents or reduces a policy change if and only if P is on the same side outside the equilibrium of the bicameral game (interval $[S, N]$) as Q .

In addition, as ROMER and ROSENTHAL (1978) show, the impact of the referendum is smaller the further away the status quo or reversion point from the ideal points of the three players. The dashed line in Figure 3 represents the outcome if the status quo is equal

10. This conclusion is well accepted in political science (see for example, MÖCKLI 1993), however not as theoretically derived conclusion but rather as a stylized fact. A different explanation for the status quo bias gives URSPRUNG (1994) who argues that the status quo preserving function of the referendum is due to a status quo bias in individual decisions in an environment of incomplete information. In my model, the bias is a consequence of the decision rules and occurs even if all actors are completely informed. See section 6 for a discussion of the impact of uncertainty.

to zero. For most possible locations of P , the shift of the status quo from Q to zero reduces the impact of the people. The reason is that (for $P > Q$) the median voter dislikes a reversion to zero more than to Q what allows the agenda setters (N and S) to realize a policy closer to their preferences. As a consequence, sunset clauses which set the reversion point to zero *can reduce* the impact of the referendum.

Concluding this section, let me point out some comparative static results. First of all, many changes in the ideal points P , S , N do not translate into policy changes. Assume that P and Q are between S and N . If N and P move to the right but S does not shift, no policy change occurs. The status quo will only be replaced if the ideal points of the players move in such a way that Q shifts outside the set of points included between P , S and N . This is the case for example if P , S and N all shift enough in the same direction. Second, the induced policy modification typically will not be marginal but rather substantial. Since once the status quo is outside the equilibrium range, the win set is typically large in the sense that a substantial policy change can be realized. Hence, as long as Q is an equilibrium point, nothing happens. If the range of equilibrium outcomes moves such that Q is outside, a discontinuous policy change occurs. This result corresponds with an observed pattern in politics in which a policy is stable for a long time but, at some point in time, a substantial reform takes place.^{11, 12}

3.2 Two-dimensional choices

The introduction of a second issue changes the nature of the results for majority based voting systems fundamentally, inasmuch as no equilibrium exists in general. In the following, I investigate whether the results found for one-dimensional decisions are valid in two-dimensional choices as well. First, I look at the bicameral game and then add the referendum.

HAMMOND and MILLER (1987) demonstrate that, in the case of two dimensions, bicameral games have an equilibrium in certain conditions. To describe these conditions let me first introduce the concept of bisectors. For an odd number of members, a *chamber bisector* is a line through two ideal points of members of the same chamber such that the number of ideal points lying on this line plus the number of ideal points to one side constitute a majority and the number of ideal points on the line plus the ones on the other side constitute a majority. A *bicameral bisector* is a line through the ideal points of two members from different chambers such that the ideal points on the line plus the ideal points on either side of the line constitute a joint majority in both chambers. For an odd number of members in both chambers, the bisectors are *attractive both ways*, that is, for

11. Discontinuous policy changes in American politics are analyzed for example by FEREJOHN (1986), WEINGAST (1981) and WEINGAST and MORAN (1983).
12. I have not mentioned the executive who applies the statutes. Obviously, the larger the set of equilibrium points in the bicameral-referendum game, the larger the set of politically viable interpretations by the executive or the larger its discretion (see FEREJOHN and SHIPAN [1990]).

Figure 4: Chamber and bicameral bisectors with equilibrium

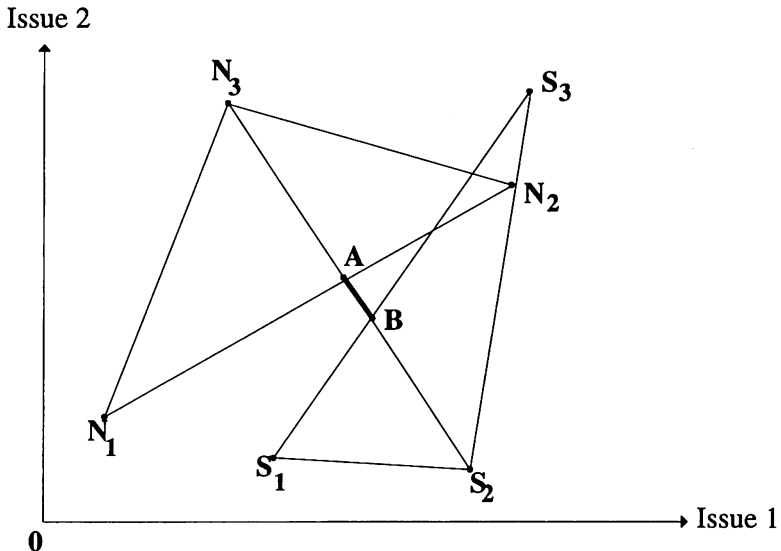

any point not on the bisector there is a point on the bisector that is preferred by a majority. These definitions are illustrated in Figure 4 and 5 with the two chambers having each three members (S_1, S_2, S_3 and N_1, N_2, N_3). The chamber bisectors are drawn in Figure 4. Since there are only three members in each chamber the chamber bisectors are the lines between the ideal points of each member. In Figure 4, there is just one bicameral bisector, namely the line through N_3S_2 while three bicameral bisectors exist in Figure 5.

For an odd number of members, an equilibrium exists only if

- (i) in the case of three or more bicameral bisectors they intersect all at the same point; or if
- (ii) in the case of one bicameral bisectors there is a point x on the bicameral bisector such that chamber bisectors from only one chamber intersect at the bicameral bisector in each direction from x (Theorems 2 and 3 in HAMMOND and MILLER 1987).

Condition (ii) is illustrated in Figure 4. The set of points between A and B on the bicameral bisector N_3S_2 is the equilibrium because majorities in both chambers want to move in opposite directions. Condition (ii) requires that the two chambers are substantially heterogeneous. Otherwise, an equilibrium exists only if condition (i) is met, a case that is unlikely to occur (see Figure 5 where no equilibrium exists). However, if there is

Figure 5: Bicameral bisectors without equilibrium

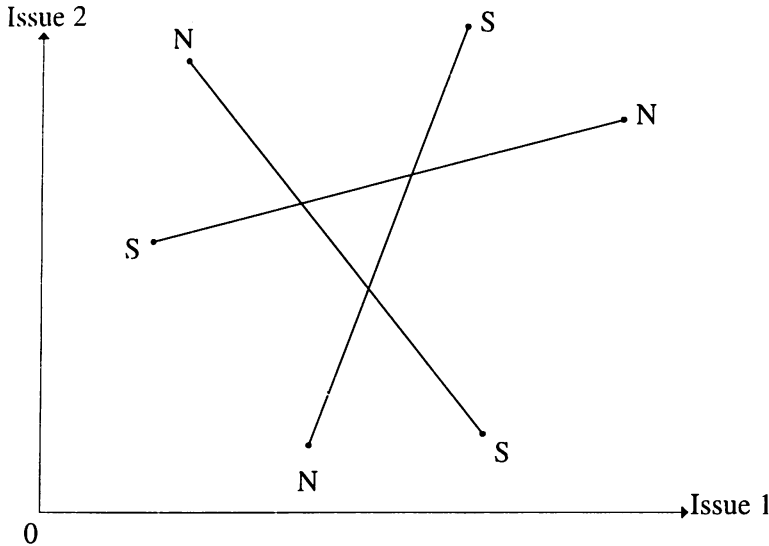

an even number of members in one or both chambers, HAMMOND and MILLER conjecture that there is usually an equilibrium.

To introduce the referendum into the bicameral game I regard voters as a third player which can veto any changes. The following proposition is easily proved:

PROPOSITION 3: An equilibrium in the bicameral-referendum game exists if an equilibrium exists between at least one pair of the three players.

By definition of the bicameral-referendum game, any change has to be approved by all three players (both chambers and the people). If a point is an equilibrium in the interaction between two of these players, a change would make at least one of the two players worse off and she would therefore veto it. With the introduction of a third veto player, a point inside the two player-equilibrium remains an equilibrium point. Hence, if an equilibrium exists between a pair of the three players, this point is also an equilibrium in the bicameral-referendum game.

To keep the illustration tractable I depict only three voters (P_1, P_2, P_3) which could stand for three homogeneous groups of voters of equal number. Figure 6 shows a situation in which an equilibrium in the bicameral-referendum game exists although there is no bicameral equilibrium. The voters have an equilibrium with each of the chambers (line AB on the bicameral bisector P_2S_3 with the Council of States and line GF on the bicameral bisector P_2N_2 with the National Council). However, the equilibrium of the bicameral-referendum game is much larger than the sum of the two-player equilibria and comprises the area $ACDEG$. A point inside this area cannot be replaced by another point. For example, a point that the two chambers prefer to C lies on the bicameral

Figure 6: Equilibrium in the bicameral-referendum game

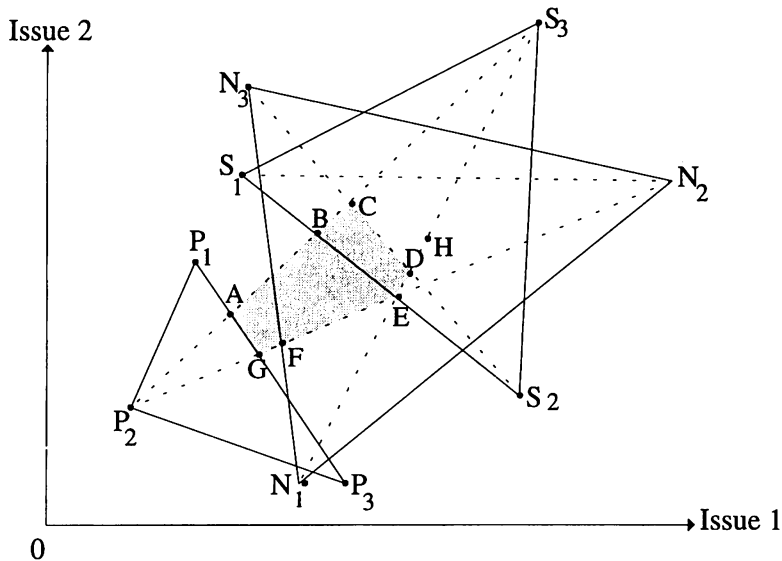

bisector N_1S_3 , as for instance point H . However such a change would be vetoed by the people. In contrast, H is outside of the equilibrium because majorities in both chamber and the people would prefer a point on N_3S_2 .

Obviously, an equilibrium in the bicameral-referendum game does not always exist. If the ideal points of both chambers and the people are identically distributed, the bicameral-referendum game is the same as a unicameral system and no equilibrium exists. The more heterogeneous the distribution of ideal points among the three players, the more likely is an equilibrium.¹³

Summarizing, in a bicameral system with referendum, an equilibrium is more likely to exist and if it exists the set of undominated points is often larger than in a bicameral system without referendum. The larger the equilibrium, the more likely is that the status quo is inside the equilibrium and no policy change can occur. Consequently, the introduction of the referendum tends to increase policy stability for legislative choices not only in decisions involving one dimension but also in two-dimensional choices.

13. Furthermore, it is possible to find situations, in which no equilibrium exists between any two players but there is an equilibrium in the interaction between all three. However, I have not been able to state the necessary conditions for this case.

Figure 7: Equilibrium in one-dimensional constitutional choice



4. CONSTITUTIONAL DECISION RULES

The Swiss Constitution can be changed either completely or partially. A proposal can be put forward either by the parliament (that is by a majority in both houses) or by any group of people that has support for their proposal from 100,000 citizens (popular initiative). A proposal is only allowed to include a single issue otherwise it can be invalidated by the parliament.¹⁴ For a proposed amendment to be accepted it has to be approved by the majority of the voters nationwide *and* by majorities in a majority of the cantons (qualified majority rule). Since the only complete revision in 1874, the Constitution has been amended 136 times (as of May 31, 1995). The following analysis examines the impact of the decision rules on stability, first, for choices about one issue and, second, for choices involving two issues.

4.1 One-dimensional choices

Because of the existence of the popular initiative, the parliament no longer possesses its monopoly for proposals as it does in the legislative process. Consequently, in constitutional decisions only two players are decisive, the median voter nationwide and the median voter in the median canton. The following proposition identifies the equilibrium of the qualified majority rule for one-dimensional choices:

PROPOSITION 4: For one-dimensional decisions, the qualified majority requirement generally expands the set of equilibrium points in comparison with simple majority rule.

Since cantons differ in their economic structure and are of unequal size, the ideal point of the median voter in the nationwide electorate (P) and the ideal point of the median voter in the median canton (C) are different in general, as depicted in Figure 7. While with simple majority rule the equilibrium is the ideal point of the median voter (P), the qualified majority rule increases the range of the equilibrium which includes all points

14. Article 121.3 of the Swiss Constitution states: «If an initiative proposes to revise or to add to the Constitution several issues, each issue has to be formulated as a separate initiative» (translation by the author). The parliament has used the power to invalidate popular initiatives on this ground only three times, namely in 1955, 1977 and 1995.

in the interval $[C, P]$. These points are stable because the majority of the cantons and the majority of the people want to move in opposite directions and therefore no constitutional change can take place. The size of the equilibrium increases the larger the distance between C and P which expands with diverging economic and demographic development among others.¹⁵

The magnitude of a possible policy change is determined by the location of the status quo (Q). In Figure 7, not all points of the interval $[C, P]$ can defeat Q but only those in the win set $[W(Q)=(Q, C(Q))]$. If the parliament had the exclusive right to make constitutional proposals it could choose a point inside the win set or, if the ideal point of one chamber is in Q or to the left of Q , not make any proposal at all. However, because the support of only about two percent of the voters is sufficient to put a popular initiative on the ballot, the agenda setting process is quite competitive. Consequently, the player who is first in making a proposal which is inside the win set of the status quo and inside the equilibrium has an important *first mover advantage*. Since her proposal is inside the win set it defeats the status quo and because it is inside the equilibrium, no future proposition can successfully challenge it. Consequently, the parliament has an incentive to change the status quo if it is outside the equilibrium. In fact, since 1891 (the year in which the popular initiative for a partial revision of the constitution was introduced), 77 percent of all partial revisions of the constitution (102 out of 132) have been initiated by the parliament (as of May 31, 1995).

A particular procedure allows the parliament to make a counter-proposal to a popular initiative.¹⁶ Unless the organizing group withdraws the initiative both proposals are put on the ballot at the same time. The citizens can vote in favor of one or both proposals and have to decide which proposal they prefer in case both proposals are approved. A proposal is approved if it receives the support of a majority of the people and the cantons. If both proposals are accepted by a qualified majority, the separate question becomes decisive. If a qualified majority prefers one to the other, the preferred one becomes law. If the majority of the canton favors one proposal and the majority of the people favors the other, the status quo prevails. This procedure has the following effect:

PROPOSITION 5: The right of the parliament to make a counter-proposal strengthens the influence of the parliament if the ideal points of both chambers and the status quo are on the same side outside the equilibrium range.

15. As GERMANN (1991 and 1994) correctly argues, the regional unequal population growth in Switzerland, with the large cantons growing faster than the small ones, has increased the constitutional stability by raising the distance between C and P . GERMANN (1994, 135) reports that six out of the seven votes in which the majority of the people preferred a change and the majority of the cantons preferred the status quo occurred after 1970.
16. The described procedure has been in force since 1987. Before, the voters had to choose one out of three possibilities (status quo, initiative and counter-proposal). Only if either the initiative or the counter proposal were supported by a majority of the people and the cantons the amendment was approved. Otherwise, the status quo prevailed.

Consider again Figure 7 where I simplify the exposition by assuming that the ideal points of the median members in both chambers of the parliament are identical and at point N . A group with an ideal point to the right of P wants to move the constitutional issue as much to the right as possible. Without the threat of a counter-proposal the largest change the group can achieve is from Q to $C(Q)$ because a policy to the right of $C(Q)$ would not find the support of a majority of the cantons. In Figure 7, a policy reform to $C(Q)$ leaves the parliament worse off than at Q . However, with the right to make counter-proposals the parliament can avoid such a change by making a counter-proposal at point C , its most preferred policy inside the equilibrium. Subsequently, both proposals receive support by a qualified majority against Q . Assuming sincere voting, a majority of the cantons prefers the counter-proposal while a majority of the people favors the original proposal.¹⁷ According to the rules, Q prevails which leaves the parliament better off than at $C(Q)$. To avoid a counter-proposal the group has to pick the point C . If the group chooses a point to the right of C the parliament can always counter by proposing C . This leaves the group with the choice either to withdraw their proposal and thereby realizing C or to leave the proposal on the ballot and both proposals failing. Since the group prefers C to Q it withdraws.¹⁸ Concluding, the right to make counter-proposals constrains the feasible set of successful popular initiatives as long as the parliament has an incentive to defend the status quo.

4.2 Two-dimensional choices

Simple majority rule does not have an equilibrium in two-dimensional choices and the same is true in general for the qualified majority rule in the Swiss Constitution. Although no equilibrium exists, the qualified majority rule can decrease the win set and thereby excludes some policy changes which could occur under a simple majority rule. Figure 8 illustrates this conclusion for the simplest case of five voters each belonging to one of three cantons. With a simple majority rule the win set of the status quo is the shaded area. If the voters are divided into three cantons such that voter 1 and voter 2 are one canton each and voters 3, 4 and 5 constitute the third canton, the win set is reduced to include only the heavily drawn part of the shaded area. For example, the ideal point of voter 4 which is preferred by a majority of the voters (3, 4, and 5) against the status quo is opposed by cantons 1 and 2 and therefore is outside the win set of the qualified majority rule. However, if the voters are divided differently, for example voter 2 and voter 4 are

17. Even with sophisticated voting there exists a coordination problem. The median voter in the median canton and the median voter nationwide are better off by supporting the *same* proposal. But such a coordination in their voting behavior is unlikely to occur.
18. However, if the interaction between the same players is repeated over time a group can build a reputation of not withdrawing and thereby becomes able to pick a point between C and $N(Q)$ without provoking a counter-proposal. Notice that if the group does not withdraw its proposal the status quo prevails which is also costly for the parliament which prefers its own proposal at C to the status quo.

Figure 8: Win set with simple and qualified majority rule

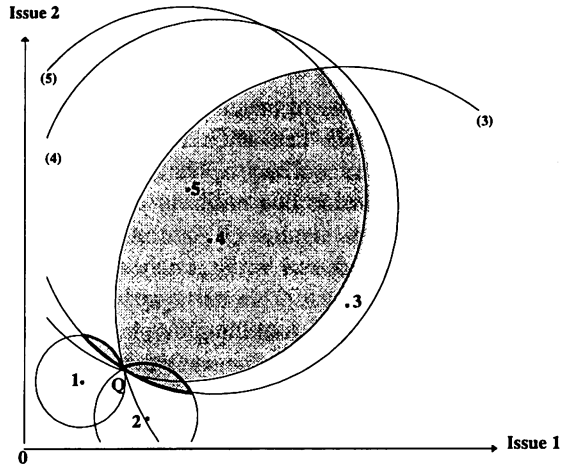

a canton each and voters 1, 3, 5 are the third canton, the win set of the simple and qualified majority rule are identical.

Besides the qualified majority rule, the Constitution requires that a proposed amendment has to include one issue only. This condition transforms a two-dimensional choice into two one-dimensional decisions. Not surprisingly, an equilibrium exists in an issue-by-issue majority rule (see ORDESHOOK [1986], 250). Consider Figure 9 with the same ideal points of five voters as in Figure 8. If voting is restricted to issue 1, voter 5 is in the median position and therefore X_1 cannot be beaten. In an independent vote on the second issues, X_2 is the undominated position with person 3 being the median voter. Consequently, point E is the *issue-by-issue median* which is stable as long as only motions along one issue at a time are considered. E is the equilibrium of a simple majority rule with single issue requirement. With this observation, I state the following proposition:

PROPOSITION 6: With a single issue requirement for constitutional amendments, an equilibrium exists and the qualified majority rule increases the size of the set of equilibrium points compared to the simple majority rule if the preferences of the median voter nationwide and the median voter in the median cantons diverge.

Considering Figure 9, I assume again that voters are divided the following way: voter 1 and 2 represent canton 1 and 2 respectively and voters 3, 4 and 5 constitute the third canton. Fixing the second issue at X_2 , the line between F and E represents the equilibrium for choices about the first issue because a movement from F toward E would be vetoed

Figure 9: Equilibrium with single issue requirement and qualified majority rule

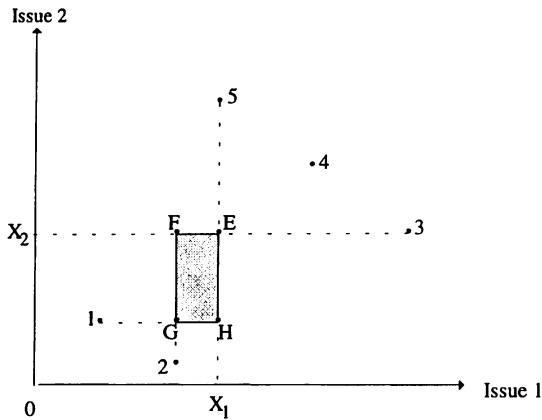

by canton 1 and 2 and the reverse movement would be rejected by a majority of the voters (3, 4, 5). If the status quo is between *E* and *H*, no change of the second issue is possible because of the opposing interests of median voter 3 and median canton 1. As a result, the equilibrium comprises all points inside the rectangle *EFGH*. The size of the equilibrium increases the larger the divergence between the median voter nationwide and the median voter in the median canton on each issue.

Summarizing, the single issue requirement causes an equilibrium to exist. The qualified majority rule together with different interests between small and larger cantons enlarges the equilibrium and thereby increase the stability of the constitution. The importance of the single issue requirement stands in contrast to its lax enforcement. The parliament has the right to invalidate popular initiatives that violate the single issue requirement. However, this happened only three times. Furthermore, most amendments are proposed by the parliament that has to observe the single issue requirement too but, in those cases, the compliance cannot be enforced. In the past, there have been several proposals that violated the single issue requirement.¹⁹

19. For example the two popular initiatives in 1899 and 1939 which proposed a popular election of the executive and an increase in the number of executive members at the same time. A more important violation was an approved amendment in 1947 (proposed by the parliament) which granted regulatory power to the federal legislators in many domains including agriculture, small businesses, regional and social as well as antitrust policy.

5. ANALYSIS OF REFORM PROPOSALS

This model of political interaction can be used to assess the impact of reform proposals on political stability. Of course, stability is usually not the goal of reform proposals. However, the degree of stability is decisive for the political outcome and, therefore, reformers should know what the consequences of their proposals are. Notice that in a stable system a change of the status quo is less likely to occur but once a policy change takes place it is more durable than in a less stable political process. In the following, I concentrate on two issues, namely on modifications in the optional referendum for legislative decisions and on the introduction of a constitutional review of statutes by the Federal Court (for a detailed discussion see MOSER [1996]). On both issues, modifications are suggested in the constitutional proposal by the Federal executive (see BUNDESRAT [1995]).

5.1 *Optional referendum for legislative decisions*

The extent of and the requirements for the optional referendum are controversial. On the one hand, some scholars advocate to reduce its impact, as for example GERMANN (1990). He recommends to give the parliament the right to decide whether a referendum can take place. His proposal would replace the optional referendum with a decisive plebiscite. But also an integration into the European Union would reduce (although not eliminate) the range of statutes that could be challenged by a referendum (see SCHINDLER 1990). On the other hand, KÖLZ and MÜLLER (1990) among others would like to extend the optional referendum to financial expenditures above a certain limit, as it is common in many cantons.

The consequences of modifying the optional referendum for political stability are straightforward and follow from propositions 1 and 3. The smaller (larger) the impact of the optional referendum, the smaller (larger) the set of equilibrium points what implies a less (more) stable political system. The proposed plebiscite by GERMANN, for instance, would in fact transform the political structure into a pure bicameral system.

5.2 *Constitutional review of federal statutes*

Since the Federal Court lacks the power to review the constitutionality of federal statutes, a large number of scholars favors the introduction of such a review.²⁰ Also the constitutional proposal of 1995 suggests granting the Federal Court the right to review federal

20. See for example AUER (1991), BORNER, PORTER, WEDER and ENRIGHT (1991), KÖLZ and MÜLLER (1990) and MOSER (1991). In contrast, BLANKART (1994) argues that initiative and referendum are a preferable substitute for a constitutional court.

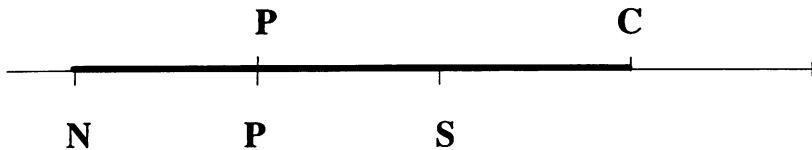
Figure 10: Comparison of the equilibrium in legislative and constitutional decisions

statutes. Let me modify the model such as to assess the impact of a judicial review of statutes on policy stability. For simplicity, I consider only one-dimensional choices.

Using the results of the previous analysis, Figure 10 depicts an example of a structure-induced equilibrium for constitutional decisions (the interval $[P, C]$) and for legislative decisions (the interval $[N, S]$). These equilibria are in general not identical. Since the median voter (P) is relevant in both decisions processes, both equilibria have at least one common point. In the case of no constitutional review of statutes, the legislators are not bound formally by the constitution and any point inside the legislative equilibrium is feasible.

By introducing a judicial review of statutes, the Federal Court becomes a decisive player. Following FEREJOHN and WEINGAST (1992), I distinguish two interpretive stances that a court might adopt.

- (i) Naive textualist. The court interprets the constitution as close as possible to that desired by the enacting majorities, or literally if the constitution is precise.
- (ii) Constrained policy advocate. The court has well defined preferences over policy outcomes and attempts to impose its own preferences. However, the court is constrained by the assumption that the court dislikes if its interpretation is modified by a formal constitutional revision. The court is sophisticated (as opposed to naive) and takes into account whether its interpretations are politically viable.²¹

If the court acts as a naive textualist any statutes that do not correspond to the constitutional status quo (Q) will be modified such that they conform to the constitution.²² Even if Q is outside the equilibrium for constitutional decisions, a naive court

21. The assumption of the court acting as a sophisticated policy advocate is often used in models of the interaction between legislator and court (see MARKS 1988, GELY and SPILLER 1992). Although this assumption might appear extreme, the relative independence of judges, vague constitutional provisions and the intransparent decision making by the Federal Court give large discretion to the interpreting judges and allows them to follow at least partially their policy preferences (on this point see also KIRCHGÄSSNER 1992).
22. I assume that the court can give a constitutionally correct interpretation of a statute or that the court invalidates unconstitutional parts of the statute and replaces them with provisions derived from the constitution. Such a behavior seems more likely if the court considers individual cases than if it judges the constitutionality of new statutes.

tries to maintain Q . In this case, the constitutional decision makers become active and replace Q by a policy located in the interval $[P, C]$ which then will be enforced again by the court. Constitutional review by a court behaving as a textualist strongly constrains the legislative process to the constitutional choice. Whether such a judicial review increases or decreases policy stability depends on the relative size of the equilibria for constitutional and legislative decisions. Referring to Figure 10, if the interval $[P, C]$ is smaller than the interval $[N, S]$, the constitutional process provides less stability than the legislative one, and vice versa. The point is that the introduction of a judicial review of legislation alone does not guaranty more durable policies even if the court follows precisely the instructions of the constitutional decision makers.

A court behaving as a constrained policy advocate can choose any point inside the equilibrium of the constitutional decision making. The interval between P and C becomes the set of *political viable interpretations*, i.e., those that would not provoke a response by the constitutional decision makers. What such a court does depends upon its preferences. If its ideal point is located inside the equilibrium it will hold constitutional only those statutes that correspond to its most preferred interpretation of the constitution. Otherwise, the court will attempt to modify the statute by giving it a constitutional «correct» interpretation or by requiring the legislators to change the statute such that it is in accordance with the court's ideal point. If the court's ideal point is outside the equilibrium for constitutional decisions the court is constrained and will enforce either C or P .

A constitutional review by a court acting as a policy advocate reduces policy stability compared to the present legislative procedures. While in the latter three veto players exist (both chambers and the people), the durability in the former depends only on the stability of the preferences of one player. If the court's ideal point is inside the equilibrium of the constitutional decision rules any change in the court's position translates into a policy change. If the court is constrained (because its ideal point is not politically viable) the policy outcome depends on the preference of the constraining player (either P or C).

Concluding, the introduction of a judicial review of statutes by the Federal Court is likely to reduce policy stability. This effect will be stronger the more the court acts (or has the freedom to act) as a policy advocate.²³

23. If the Federal Court behaves as a policy advocate, the election of judges would become more important political decisions than they are presently. Since federal judges have to be reelected every four years, the threat of not being reelected would constrain the judges further, which is not considered in this model.

6. UNCERTAINTY AND COSTLY REFERENDA

To keep the model simple I have made two assumptions which I discuss here briefly. First, the model does not take into account the costs of collecting the signatures necessary for a referendum or a popular initiative. Second, it is assumed that all players have perfect and complete information, that is, each player knows the preferences of the other players and the moves occur in sequence. With this assumption, the parliament never passes a statute that can be vetoed by the people and therefore a referendum never takes place in equilibrium. Furthermore, in such a setting interest groups activities cannot be addressed. By introducing uncertainty it becomes possible to take into account the fact that referenda occur (against about 7 percent of all statutes) and that referenda may fail as well as to model how interest group activities influence legislative choices (see also HUG 1996). One approach, chosen by URSPRUNG (1994), is to assume voters are uninformed about the consequences of policy choices and that interest groups can change voters' decisions through propaganda. In such a structure, the outcome depends to a large part on the relative strength of conservative and progressive interest groups. It becomes possible that voters reject a legislative proposal that they would prefer if they were fully informed about its consequences. However, these results are derived by using strong assumptions: First, uninformed voters are presumed to make systematic mistakes by voting for the status quo even if fully informed they would prefer the proposed legislative change.²⁴ Second, URSPRUNG implicitly assumes that parliamentary decisions are immune or less likely to be influenced by the same interest groups. A second approach to model uncertainty is to assume that the parliament (agenda setter) has imperfect information about voters preferences (see DENZAU and MACKAY 1983, ROSENTHAL 1990) and that interest groups are better informed about voters preferences (see for example AUSTEN-SMITH and WRIGHT 1992). In this section, I briefly outline some results for legislative decisions using the second approach.

Consider a one-dimensional policy space as drawn in Figure 11 with the status quo (Q) at zero. In stage 1, the parliament chooses a proposal (x_N). To simplify the exposition, I neglect bicameral differences. The parliament knows that the ideal point of the median voter (P) is uniformly distributed on 0 and 1. In stage 2, the interest group with an ideal point at zero decides whether to launch a referendum. The interest group is assumed to know the median voter's ideal point. In the last stage, voters decide between the proposal and Q if a referendum was initiated, otherwise the proposal becomes effective. The actors' utility functions take the following form: for the interest group,

24. The public debate in direct democracies is regarded more favorably by EICHENBERGER and SERNA (1995), FREY (1994) and FREY and KIRCHGÄSSNER (1993). They argue that a referendum stimulates public discussion and thereby reduces uncertainty and can break cartels of politicians directed against voters and taxpayers. Furthermore, LUPIA (1992, 1994) points out how voters can use information cues (such as interest group endorsement or the costliness of an initiative) to make more accurate inferences about electoral or policy alternatives.

$$U_I(x) = -x - \delta c ;$$

for the median voter,

$$U_P(x) = -|x - P| ;$$

for the parliament,

$$U_N(x) = -|x - M| .$$

The utilities of all actors decrease linearly the further away the policy choice (x) is from their ideal points. The interest group has to incur cost (c) if it uses the referendum ($\delta = 1$).

The game is solved by backward induction. In the last stage, if a referendum takes place the median voter always favors the policy closer to his or her ideal point. Consequently, the interest group will only initiate a referendum in the second stage if she knows that it will be successful, $x_N > 2P$, and if it is worth doing, $x_N > c$.²⁵ The optimal strategy of the parliament depends on the location of its ideal point. In the following, I illustrate the results of this model with two examples. For the exact derivation and the general results, see the Appendix.

Figure 11: Uncertainty of the parliament about the location of the median voter's ideal point

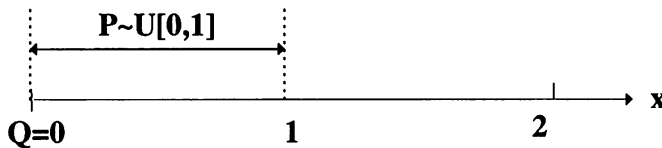

As a first case, I consider the situation in which there is no systemic difference between the ideal points of the median voter and the parliament ($N = 0.5$). The optimal proposal (x_N) depends on the cost (c) for the interest group. The optimal strategy for the parliament is to propose its ideal point, $x = 0.5$, whenever $c < 0.375$. A successful referendum is initiated in 25 percent of all cases and the proposal is defeated. However, if the parliament faces an interest group with $c = 0.4$, the optimal proposal is $x = 0.4$. In the latter case, the parliament can increase its utility by accommodating its proposal toward the interest group such that she no longer has an incentive to organize a referendum. Therefore, the parliament can realize its proposal for sure. But notice that the expected value of the

25. If the group were not perfectly informed about the median voter's ideal point, her referendum would sometimes fail.

Figure 12: Optimal proposal and expected policy if the ideal point of the parliament is at $N = 2$

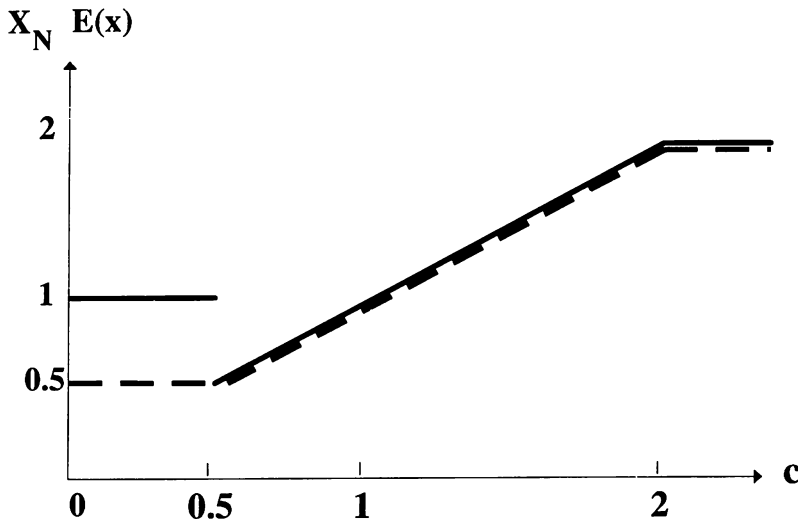

realized policy is 0.375 in the case of $c < 0.375$ while the realized policy is 0.4 if $c = 0.4$. Hence, low cost interest groups have more influence inasmuch as they reduce the expected policy more than interest groups with higher costs. However, while the parliament accommodates her proposals to higher cost groups, low cost interest groups have to use the costly referendum, as long as they cannot credibly inform the parliament on the location of the median voter's ideal point in some other way.

In the second case, I assume a systematic divergence between the median voter's preferences and those of the parliament, for example $N = 2$. The optimal proposal is

$$\begin{aligned}
 x_N &= 1 \text{ if } c < 0.5 \\
 x_N &= c \text{ if } 0.5 \leq c < 2 \\
 x_N &= 2 \text{ if } c \geq 2 .
 \end{aligned}$$

See Figure 12. Although the optimal proposal does not raise monotonically with higher c (solid line), the *expected* policy increases with higher costs (dashed line). Consequently, if institutional reforms increase c (for example by raising the required number of signatures) the parliament can deviate more from the preferences of the median voter. Furthermore, the number of referenda will decline but the proposals by the parliament might in fact become more conservative if c was below 0.5 and is between 0.5 and 1 after the reform.

Two further implications are worth pointing out: First, in single proposals (with no possibility to learn the median ideal point) the uncertainty constrains the parliament such that its proposals sometimes fail. If P were at 0.5 for certain, the parliament with $N = 2$ could realize 1 for certain. Because of uncertainty a referendum will take place in 50 percent of all proposals (for $c < 0.5$) with an expected value of the proposal of 0.5. Second, only conservative interest groups who want to preserve the status quo are active in legislative decision making. Progressive interest groups cannot use the referendum to credibly signal that they have better information about the location of the median voter's ideal point than the parliament. This observation has led scholars of Swiss politics (for example BORNER, BRUNETTI and STRAUBHAAR 1990, p. 170) to attribute the stability in legislative decision making to the existence of well organized (conservative) interest groups who use the referenda to veto changes in the status quo. The same observation has a completely different interpretation in my model: Conservative interest groups are active participants but they are only successful if the status quo is closer to the median voter's ideal point than the proposal by the parliament. Consequently, the interest groups play a *beneficial role* inasmuch as they can turn down parliamentary proposals that deviate much from voters' preferences. The lower the group's organization cost and the better the group is informed about voters' preferences, the more successful she is in constraining the parliament. The larger the bias between parliament's and voters' preferences and the more uncertain the Parliament is about voters' preferences, the more beneficial is the potential use of a referendum by interest groups.

7. CONCLUSIONS

The purpose of this paper is to develop a model of the political system of Switzerland that can explain policy change and policy stability and analyze the effects of institutional reforms. The paper identifies two attributes of the Swiss political system that are decisive for stability. With respect to legislative decisions, the combination of the bicameral system with the optional referendum makes it more likely that an equilibrium exists in decisions involving one or two dimensions. If an equilibrium exists it is larger than without referendum if the preferences of the two chambers and of the people are sufficiently diverse. Furthermore, a change of the position of one of the three players (Council of States, National Council or the people) in general is not sufficient to induce a policy change. In the case of constitutional decisions, stability is created by the requirement that each proposed amendment has to include one issue only. Stability is enlarged by the qualified majority rule which requires the support of a majority of the people and of a majority of the cantons for a constitutional change. The introduction of uncertainty about voters' preferences does not modify these results qualitatively but allows to give a more accurate description of the equilibrium strategies (with successful referenda taking place) and to account for the role of interest groups.

Since the Federal Court lacks the right to review federal legislation, there is no mechanism to enforce the Constitution in the legislative process. An introduction of a judicial review of federal statutes is unlikely to induce more durability but rather the opposite. Such a reform would give more weight to the constitutional decision process. However, the legislative process tends to be more stable than the constitutional one because (i) there are three veto players in the legislative process and only two in the constitutional process and (ii) because statutory proposals can only be introduced by members of the two chambers and by the executive but not by a group of people, as with the popular initiative for constitutional proposals. Moreover, the durability of a procedure with judicial review depends to a large extent on the interpretative stance a court adopts.

APPENDIX: REFERENDUM GAME

The game comprises three stages:

1. The parliament chooses a proposal x_N .
2. The interest group decides whether to organize a referendum at a cost c .
3. If a referendum takes place, the median voter chooses between the status quo (at zero) and the proposal (x_N). Otherwise, the proposal becomes the new status quo.

The game is solved by backward induction. In the last stage, the median voter approves the proposal if $x_N < 2P$, otherwise he or she votes against the proposal. Since the interest group knows the ideal point of the median voter (P), she will only initiate a referendum if it is successful and if it is worth doing. Therefore, the interest group organizes a referendum only if $x_N > 2P$ and $x_N > c$. In the first stage, the parliament knows these reactions and maximizes its expected utility (or minimizes its loss of utility) with respect to its proposal x_N :

$$EU_N(x_N) = -|x_N - N| (1 - x_N/2) - |0 - N| (x_N/2) \quad (\text{A1})$$

The parliament's strategy depends on the existence of positive costs for initiating the referendum.

1. No costs ($c = 0$)

There are three strategies for the parliament which can be distinguished: $x_N = N$, $x_N < N$, and $x_N > N$. The last case will never be chosen such that I focus only on the first two cases. If the parliament chooses its ideal point as its proposal ($x_N = N$) then its expected utility is

$$EU_N(x_N = N) = -N^2/2. \quad (\text{A2})$$

Maximizing the expected utility (A1) with respect to x_N and assuming that the proposal x_N is smaller than N leads to $x_N = 1$ as the optimal proposal. The expected utility in this case is

$$EU_N(x_N = 1) = 1/2 - N. \quad (A3)$$

The comparison of the expected utilities in (A2) and (A3) reveals that the optimal choice (for $c = 0$) is $x_N = N$ if $N \leq 1$ and $x_N = 1$ if $N > 1$.

2. Positive costs ($c > 0$)

With positive costs, the interest group will only initiate a referendum if the utility loss of the proposal by the parliament (x_N) is larger than the utility loss of organizing the referendum (c). Again, the two situations $x_N = N$ and $x_N < N$ need to be considered separately. If N is between 0 and 1 we know that in the absence of costs, the parliament would propose its ideal point and the expected utility were $EU_N(x_N = N) = -N^2/2$, as in (A2). I will show that the parliament can increase its utility by proposing c instead of N if $c < N$ but not too small. If it proposes c then the parliament realizes its proposal for sure, that is its utility becomes

$$EU_N(x_N = c) = -(N - c). \quad (A4)$$

(A4) exceeds (A2) if $c > N - N^2/2$. Therefore, the optimal proposal for a parliament with N between 0 and 1 is

$$\begin{aligned} x_N &= c && \text{if } N - N^2/2 < c < N \\ x_N &= N && \text{otherwise.} \end{aligned}$$

In the second case in which $N > 1$ such that the parliament proposes $x_N < N$, the expected utility for $x_N = 1$ is $EU_N(x_N = 1) = 1/2 - N$, as in (A3). If the parliament chooses c as its proposal, its utility is given by (A4). Solving for c such that the expected utility is equal in (A3) and (A4) yields $c = 1/2$. Therefore, the optimal strategy for the parliament with $N > 1$ is

$$\begin{aligned} x_N &= 1 && \text{if } c < 1/2 \\ x_N &= c && \text{if } 1/2 \leq c < N \\ x_N &= N && \text{if } c \geq N. \end{aligned}$$

REFERENCES

- ALESINA, ALBERTO and GUIDO TABELLINI (1990) «A Positive Theory of Fiscal Deficits and Government Debt», *Review of Economic Studies*, 57, 403-414.
- AUER, ANDREAS (1990) «Rückwirkungen der europäischen Integration auf die schweizerische Verfassungsgerichtsbarkeit», *Aussenwirtschaft*, 46, 533-549.
- AUSTEN-SMITH, DAVID and JOHN R. WRIGHT (1992) «Competitive Lobbying for Legislators' Vote», *Social Choice and Welfare*, 9, 229-257.
- AXELROD, ROBERT M. (1984) *The Evolution of Cooperation*, New York: Basic Books.
- BERNHOLZ, PETER (1978) «On the Stability of Logrolling Outcomes in Stochastic Games», *Public Choice*, 33, 65-82.
- BLACK, DUNCAN (1958) *The Theory of Committees and Elections*, London: Cambridge University Press.
- BLANKART, CHARLES B. (1992) «Bewirken Referendum und Volksinitiative einen Unterschied in der Politik?», *Staatswissenschaften und Staatspraxis*, 3, 509-523.
- BLANKART, CHARLES B. (1994) «Club Governments versus Representative Governments», *Constitutional Political Economy*, 5, 273-285.
- BORNER, SILVIO, AYO BRUNETTI and THOMAS STRAUBHAAR (1990) *Schweiz AG*, Zürich: Neue Zürcher Zeitung.
- BORNER, SILVIO, AYO BRUNETTI, THOMAS STRAUBHAAR (1994) *Die Schweiz im Alleingang*, Zürich: Neue Zürcher Zeitung.
- BORNER, SILVIO, MICHAEL E. PORTER, ROLF WEDER and MICHAEL ENRIGHT (1991) *Internationale Wettbewerbsvorteile: Ein strategisches Konzept für die Schweiz*, Frankfurt: Campus.
- BRUNETTI, AYO (1992) *Politisches System und Wirtschaftswachstum*, Chur: Verlag Rüegger.
- BUNDESRAT (1995) *Reform der Bundesverfassung: Verfassungsentwurf*, Bern: EDMZ.
- COUGHLIN, PETER J. (1992) *Probabilistic Voting Theory*, Cambridge: Cambridge University Press.
- DENZAU, ARTHUR and ROBERT MACKAY (1983) «Gatekeeping and Monopoly Power of Committees: An Analysis of Sincere and Sophisticated Behavior», *American Journal of Political Science*, 27, 740-761.
- EICHENBERGER, REINER and ANGEL SERNA (1995) «Random Errors, Dirty Information, and Politics», forthcoming, *Public Choice*, 86, 137-156.
- FELD, LARS (1995) «Formal Fiscal Restraints or Direct Democracy», Manuscript, University of St. Gallen.
- FEREJOHN, JOHN A. (1986) «Logrolling in an Institutional Context: A Case Study of Food Stamp Legislation», in GERALD C. WRIGHT, LEROY N. RIESELBACH and LAWRENCE C. DODD, eds., *Congress and Policy Change*, New York: Agathon, 223-253.
- FEREJOHN, JOHN A. and CHARLES SHIPAN (1990) «Congressional Influence on Bureaucracy», *Journal of Law, Economics, and Organization*, 6, 1-20.

- FEREJOHN, JOHN A. and BARRY R. WEINGAST (1992) «A Positive Theory of Statutory Interpretation», *International Review of Law and Economics*, 12, 263-279.
- FREY, BRUNO S. (1994) «Direct Democracy: Politico-Economic Lessons from Swiss Experience», *American Economic Review*, 84, 338-342.
- FREY, BRUNO S. and GEBHARD KIRCHGÄSSNER (1993) «Diskursethik, Politische Ökonomie und Volksabstimmungen», *Analyse und Kritik*, 15, 129-149.
- FREY, BRUNO S. and GEBHARD KIRCHGÄSSNER (1994) *Demokratische Wirtschaftspolitik*, 2. Edition, München: Vahlen.
- GELY, RAFAEL and PABLO T. SPILLER (1992) «The Political Economy of Supreme Court Constitutional Decisions: The Case of Roosevelt's Court-Packing Plan», *International Review of Law and Economics*, 12, 45-67.
- GERMANN, RAIMUND E. (1990) «Pour une Constitution fédérale «Euro-compatible»», *Zeitschrift für Schweizerisches Recht*, I, 1-15.
- GERMANN, RAIMUND E. (1991) «Die Europatauglichkeit der direktdemokratischen Institutionen der Schweiz», *Schweizerisches Jahrbuch für politische Wissenschaft*, 31, 257-269.
- GERMANN, RAIMUND E. (1994) *Staatsreform: Der Übergang zur Konkurrenzdemokratie*, Bern: Haupt.
- HAMMOND, THOMAS H. and GARY J. MILLER (1987) «The Equilibrium of the Constitution», *American Political Science Review*, 81, 1155-1174.
- HUG, SIMON (1996) «Referendums Around the World: Why do they Occur?», *Manuscript*, University of Geneva.
- KIRCHGÄSSNER, GEBHARD (1992) «Towards a Theory of Low-Cost Decisions», *European Journal of Political Economy*, 8, 305-320.
- KLEINWEFERS, HENNER (1995) ««Verwesentlichung» der Politik durch Einschränkung der direkten Volksrechte? Eine Auslegeordnung der Probleme und ein Vorschlag aus ökonomischer Sicht», *Manuscript*, University of Freiburg.
- KÖLZ, ALFRED and JÖRG PAUL MÜLLER (1990) *Entwurf für eine neue Bundesverfassung*, Basel: Helbing und Lichtenhahn.
- LINDER, WOLF (1994) *Swiss Democracy: Possible Solutions to Conflict in Multicultural Societies*, New York: St. Martin's Press.
- LUPIA, ARTHUR (1992) «Busy Voters, Agenda Control, and the Power of Information», *American Political Science Review*, 86, 390-403.
- LUPIA, ARTHUR (1994) «The Effect of Information on Voting Behavior and Electoral Outcomes: An Experimental Study of Direct Legislation», *Public Choice*, 78, 65-86.
- MARKS, BRIAN A. (1988) «A Model of Judicial Influence on Congressional Policymaking: Grove City V. Bell», Working Paper in Political Science, 88-7, Hoover Institution, Stanford.
- MCKELVEY, RICHARD D. (1976) «Intransitivities in Multidimensional Voting Models and Some Implications for Agenda Control», *Journal of Economic Theory*, 12, 472-82.

- MÖCKLI, SILVANO (1993) «Stärken und Schwächen der direkten Demokratie in der Schweiz», Beiträge und Berichte des Instituts für Politikwissenschaft an der Hochschule St. Gallen, No. 202.
- MOSER, PETER (1991) *Schweizerische Wirtschaftspolitik im internationalen Wettbewerb*, Zürich: Orell Füssli.
- MOSER, PETER (1996) «Zwischen Immobilität und Instabilität: Auswirkungen der Einführung von Gesetzesinitiative und Verfassungsgerichtsbarkeit in der Schweiz», Discussion paper, University of St. Gallen.
- MUELLER, DENNIS C. (1989) *Public Choice II*, Cambridge: Cambridge University Press.
- ORDESHOOK, PETER C. (1986) *Game Theory and Political Theory*, Cambridge: Cambridge University Press.
- ORDESHOOK, PETER C. (1992) *A Political Theory Primer*, New York: Routledge.
- POMMEREHNE, WERNER (1978) «Institutional Approaches to Public Expenditures: Empirical Evidence from Swiss Municipalities», *Journal of Public Economics*, 9, 163-201.
- PERSSON, TORSTEN and LARS E. O. SVENSSON (1989) «Why a Stubborn Conservative Would Run a Deficit: Policy with Time-Inconsistent Preferences», *Quarterly Journal of Economics*, 85, 325-45.
- RIKER, WILLIAM H. (1982) *Liberalism Against Populism*, San Francisco: W. H. Freeman.
- ROMER, THOMAS and HOWARD ROSENTHAL (1978) «Political Resource Allocation, Controlled Agendas, and the Status Quo», *Public Choice*, 33, 27-43.
- ROSENTHAL, HOWARD (1990) «The Setter Model», in JAMES M. ENELow and MELVIN J. HINICH, eds., *Advances in the Spatial Theory of Voting*, Cambridge: Cambridge University Press, 199-234.
- SCHINDLER, DIETRICH (1990) «Auswirkungen der EG auf die schweizerische Staatsstruktur», *Wirtschaftspolitische Mitteilungen*, 2, 1-18.
- SHEPSLE, KENNETH A. (1979) «Institutional Arrangements and Equilibrium in Multidimensional Voting Models», *American Journal of Political Science*, 24, 27-59.
- SHEPSLE, KENNETH A. (1986) «Institutional Equilibrium and Equilibrium Institutions», in HERBERT F. WEISBERG, ed., *Political Science: The Science of Politics*, New York: Agathan Press, 51-81.
- SHEPSLE, KENNETH A. and BARRY R. WEINGAST (1984) «Uncovered Set and Sophisticated Voting Outcomes with Implications for Agenda Institutions», *American Journal of Political Science*, 28, 49-74.
- SHEPSLE, KENNETH A. and BARRY R. WEINGAST (1987) «The Institutional Foundation of Committee Power», *American Political Science Review*, 81, 85-104.
- STEUNENBERG, BERNHARD (1992) «Referendum, Initiative, and Veto Power», *Kyklos*, 45, 501-529.
- TSEBELIS, GEORGE (1995) «Decisionmaking in Political Systems: Comparison of Presidentialism, Parliamentarism, Multicameralism, and Multipartism», *British Journal of Political Science*, 25, 289-325.

- URSPRUNG, TOBIAS (1994) *Propaganda, Interessengruppen und direkte Demokratie*, Heidelberg: Physika-Verlag.
- WEINGAST, BARRY R. (1981) «Regulation, Reregulation, and Deregulation: the Political Foundation of Agency Clientele Relationship», *Law and Contemporary Problems*, 44, 147-77.
- WEINGAST, BARRY R. and WILLIAM J. MARSHALL (1988) «The Industrial Organization of Congress; or, Why Legislatures, Like Firms, Are Not Organized as Markets», *Journal of Political Economy*, 96, 132-163.
- WEINGAST, BARRY R. and MARK J. MORAN (1983) «Bureaucratic Discretion or Congressional Control? Regulatory Policymaking by the Federal Trade Commission», *Journal of Political Economy*, 91, 765-800.
- WITTMANN, WALTER (1992) *Marktwirtschaft für die Schweiz*, Frauenfeld: Huber Verlag.

SUMMARY

Applying rational choice approaches of politics, I analyze why major policy changes are unlikely to occur in the Swiss political system. Legislative decision rules create durable policies by the combination of the bicameral system with the optional referendum. In contrast to normative conceptions, legislative acts tend to be more difficult to change than constitutional provisions, in spite of the qualified majority rule and the single issue requirement for constitutional amendments. Furthermore, the dominance of conservative groups in Swiss politics can be explained by the optional referendum. It is an instrument suited only for conservative groups. However, I show that this instrument is beneficial for voters.

ZUSAMMENFASSUNG

Mit Hilfe rationaler Erklärungsansätze der Politik untersuche ich, weshalb gössere politische Änderungen in der Schweiz selten zu beobachten sind. Im Gesetzgebungsprozess sorgt die Kombination des Zweikammersystems mit dem fakultativen Referendum für dauerhafte Entscheidungen. Im Gegensatz zu normativen Vorstellungen sind in der Schweiz Gesetze vielfach schwieriger zu ändern als Verfassungsbestimmungen, obwohl Verfassungsänderungen ein qualifiziertes Mehr erfordern und dem Erfordernis der Einheit der Materie genügen müssen. Die starke Stellung konservativer Gruppen ist eine Folge des fakultativen Referendums. Dieses Instrument kann nur von konservativen Gruppen benutzt werden, aber sein Gebrauch ist für die Stimmbürger vorteilhaft.

RESUME

En utilisant une approche de la politique qui considère celle-ci comme le résultat de choix rationnels, j'analyse pourquoi des changements politiques majeurs ne sont observés que rarement en Suisse. Le système législatif, à cause du bicaméralisme et du droit de référendum, tend à assurer la persistance des décisions politiques une fois que celles-ci sont prises. Les lois – en contradiction avec la conception normative – sont en Suisse plus difficiles à changer que la constitution elle-même malgré le fait qu'un tel changement requiert une majorité qualifiée et doit satisfaire à l'unité de matière. La forte position des groupes conservateurs est une conséquence du droit de référendum facultatif. Bien que cet instrument ne puisse, de par sa nature, être utilisé que par ces groupes, son existence se révèle être avantageuse pour l'électorat en général.